



MINMAX[®]

MKW180 Series

Electric Characteristic Note

MKWI80 Series EC Note

DC-DC CONVERTER 80W, Highest Power Density

Features

- ▶ Smallest Encapsulated 80W Converter
- ▶ Ultra-compact 2"×1" Package
- ▶ Ultra-high Power Density 93W/in³
- ▶ Excellent Efficiency up to 92%
- ▶ Ultra-wide 4:1 Input Voltage Range
- ▶ Fully Regulated Output Voltage
- ▶ I/O Isolation 1500 VDC
- ▶ Wide Operating Ambient Temp. Range
- ▶ No Min. Load Requirement
- ▶ Very Low No Load Power Consumption
- ▶ Under-voltage, Overload/Temperature and Short Circuit Protection
- ▶ Remote On/Off Control, Output Voltage Trim
- ▶ Shielded Metal Case with Insulated Baseplate
- ▶ UL/cUL/IEC/EN 62368-1 Safety Approval & CE Marking



Applications

- ▶ Distributed power architectures
- ▶ Workstations
- ▶ Computer equipment
- ▶ Communications equipment

Product Overview

The MKWI80 series is a cutting-edge 80W encapsulated isolated DC-DC converter in a compact 2"×1" package. With an impressive power density of 93W/in³ and efficiency up to 92%, it is tailored for space-sensitive applications without compromising on performance. The series features an ultra-wide 4:1 input voltage range, fully regulated outputs, and 1500 VDC I/O isolation, ensuring dependable operation in diverse and challenging environments. In addition, the MKWI80 series offers a wide operating temperature range, remote On/Off control, and output voltage trim functionality. Its ultra-low no-load power consumption and comprehensive protections-including under-voltage, overload, temperature, and short circuit safeguards-ensure reliable and energy-efficient operation.

Certified to UL/cUL/IEC/EN 62368-1 standards and CE marked, the MKWI80 series meets stringent global safety requirements. Available output voltage options include 5V, 12V, 15V, 24V, 48V, 54V, ±12V, and ±15V, making it an excellent choice for industrial, telecom, and other mission-critical applications demanding compact size and exceptional power performance.

Table of contents

Model Selection Guide	P2	External Output Trimming.....	P22
Input Specifications.....	P2	Test Setup.....	P23
Remote On/Off Control.....	P2	Technical Notes	P23
Output Specifications.....	P3	Remote ON/OFF Implementation	P24
General Specifications.....	P3	Packaging Information.....	P24
EMC Specifications.....	P3	Wave Soldering Considerations	P25
Environmental Specifications	P4	Hand Welding Parameter	P25
Characteristic Curves	P5	Part Number Structure	P26
Package Specifications	P21	MTBF and Reliability	P26
Recommended Pad Layout.....	P22		

Model Selection Guide							
Model Number	Input Voltage (Range)	Output Voltage	Output Current	Input Current		Max. capacitive Load	Efficiency (typ.)
				@Max. Load	@No Load		@Max. Load
	VDC	VDC	mA	mA(typ.)	mA(typ.)	μF	%
MKWI80-24S05	24 (9 ~ 36)	5	16000	3663	45	28600	91
MKWI80-24S12		12	6600	3587		4950	92
MKWI80-24S15		15	5300	3601		3150	92
MKWI80-24S24		24	3300	3587		1250	92
MKWI80-24S48		48	1670	3630		330	92
MKWI80-24S54		54	1480	3620		250	92
MKWI80-24D12		±12	±3300	3587		2500#	92
MKWI80-24D15		±15	±2660	3614		1600#	92
MKWI80-48S05	48 (18 ~ 75)	5	16000	1832	35	28600	91
MKWI80-48S12		12	6600	1793		4950	92
MKWI80-48S15		15	5300	1800		3150	92
MKWI80-48S24		24	3300	1793		1250	92
MKWI80-48S48		48	1670	1815		330	92
MKWI80-48S54		54	1480	1810		250	92
MKWI80-48D12		±12	±3300	1793		2500#	92
MKWI80-48D15		±15	±2660	1807		1600#	92

For each output

Input Specifications						
Parameter		Conditions / Model	Min.	Typ.	Max.	Unit
Input Surge Voltage (100ms. max)	24V Input Models		-0.7	---	50	VDC
	48V Input Models		-0.7	---	100	
Start-Up Threshold Voltage	24V Input Models		---	---	9	
	48V Input Models		---	---	18	
Under Voltage Lockout	24V Input Models		---	7.8	---	
	48V Input Models		---	16	---	
Start Up Time	Power Up	Nominal Vin and Constant Resistive Load	---	50	---	ms
	Remote On/Off		---	50	---	ms

Remote On/Off Control						
Parameter		Conditions	Min.	Typ.	Max.	Unit
Positive logic (Standard)	Converter On	3.5V ~ 12V or Open Circuit				
	Converter Off	0V ~ 1.2V or Short Circuit				
Negative logic (Option)	Converter On	0V ~ 1.2V or Short Circuit				
	Converter Off	3.5V ~ 12V or Open Circuit				
Positive logic Control Input Current (on)		Vctrl = 5.0V	---	0.5	---	mA
Positive logic Control Input Current (off)		Vctrl = 0V	---	-0.5	---	mA
Negative logic Control Input Current (on)		Vctrl = 0V	---	-0.5	---	mA
Negative logic Control Input Current (off)		Vctrl = 5.0V	---	0.5	---	mA
Control Common		Referenced to Negative Input				
Standby Input Current			---	---	8	mA

Output Specifications							
Parameter	Conditions / Model		Min.	Typ.	Max.	Unit	
Output Voltage Setting Accuracy			---	---	±1.0	%Vnom.	
Output Voltage Balance	Dual Output, Balanced Loads		---	---	±2.0	%	
Line Regulation	Vin=Min. to Max. @ Full Load		---	---	±0.2	%	
Load Regulation	Io=0% to 100%		---	---	±0.3	%	
Cross Regulation (Dual)	Asymmetrical Load 25% / 100% FL		---	---	±5.0	%	
Minimum Load	No minimum Load Requirement						
Ripple & Noise	0-20 MHz Bandwidth	5Vo	Measured with a 22µF MLCC	---	75	100	mV _{P-P}
		12Vo,15Vo		---	100	125	mV _{P-P}
		±12Vo, ±15Vo		---	150	200	mV _{P-P}
		24Vo		---	250	300	mV _{P-P}
		48Vo		---	280	330	mV _{P-P}
	54Vo						
Transient Recovery Time	25% Load Step Change ₍₂₎		---	---	500	µs	
Temperature Coefficient			---	---	±0.02	%/°C	
Trim Up / Down Range (See Page 22)	% of Nominal Output Voltage	Other Models	---	---	±10	%	
		54Vo Output	---	---	+5 / -15	%	
Over Load Protection	Hiccup		110	---	160	%	
Overshoot			---	---	5	%	
Short Circuit Protection	Continuous, Automatic Recovery (Hiccup Mode 0.33Hz typ.)						

General Specifications						
Parameter	Conditions		Min.	Typ.	Max.	Unit
I/O Isolation Voltage	60 Seconds		1500	---	---	VDC
	1 Second		1800	---	---	VDC
Isolation Voltage Input/Output to case	60 Seconds		1000	---	---	VDC
I/O Isolation Resistance	500 VDC		1000	---	---	MΩ
I/O Isolation Capacitance	100kHz, 1V		---	1500	---	pF
Switching Frequency			150	---	500 ⁽⁶⁾	kHz
MTBF(calculated)	MIL-HDBK-217F@25°C Full Load, Ground Benign		114,244			Hours
Safety Approval	UL/cUL 62368-1 recognition(UL certificate), IEC/EN 62368-1(CB-report)					

EMC Specifications				
Parameter	Standards & Level			Performance
EMI ₍₆₎	Conduction	EN 55032	With external components	Class A
	Radiation			
EMS ₍₆₎	EN 55035			
	ESD	Direct discharge	Indirect discharge HCP & VCP	
		EN 61000-4-2 Air ± 8kV, Contact ± 6kV	Contact ± 6kV	
	Radiated immunity	EN 61000-4-3 10V/m		
	Fast transient	EN 61000-4-4 ±2kV		
	Surge	EN 61000-4-5 ±2kV		
	Conducted immunity	EN 61000-4-6 10Vrms		
PFMF	EN 61000-4-8 100A/m for Continuous; 1000 A/m for 1 s			

Environmental Specifications					
Parameter	Conditions / Model	Min.	Max.		Unit
			without Heatsink	with Heatsink	
Operating Ambient Temperature Range Nominal Vin, Load 100% Inom. (for Power Derating see relative Derating Curves)	MKWI80-24S05, MKWI80-48S05	-40	+50	+60	°C
	MKWI80-24S12, MKWI80-24S15, MKWI80-24S24 MKWI80-24D12, MKWI80-24D15, MKWI80-48S12 MKWI80-48S15, MKWI80-48S24, MKWI80-48D12 MKWI80-48D15		+60	+70	
	MKWI80-24S48, MKWI80-24S54 MKWI80-48S48, MKWI80-48S54		+55	+65	
Case Temperature		---	+105		°C
Over Temperature Protection (Case)		---	+115		°C
Storage Temperature Range		-50	+125		°C
Humidity (non condensing)		---	95		% rel. H
RFI	Six-Sided Shielded, Metal Case				
Lead Temperature (1.5mm from case for 10Sec.)		---	260		°C

Notes

- 1 Specifications typical at Ta=+25°C, resistive load, nominal input voltage and rated output current unless otherwise noted.
- 2 Transient recovery time is measured to within 1% error band for a step change in output load of 75% to 100%.
- 3 We recommend to protect the converter by a slow blow fuse in the input supply line.
- 4 Other input and output voltage may be available, please contact MINMAX.
- 5 **It is necessary to parallel a capacitor across the input pins under hot-swap operation. Minimum Capacitance: 68µF/ 100V KZE.**
- 6 The external components might be required to meet EMI/EMS standard for some of test items. Please contact MINMAX for the solution in detail.
- 7 Do not exceed maximum power specification when adjusting output voltage.
- 8 Switching frequency changes depending on input and load.
- 9 Specifications are subject to change without notice.
- 10 The repeated high voltage isolation testing of the converter can degrade isolation capability, to a lesser or greater degree depending on materials, construction, environment and reflow solder process. Any material is susceptible to eventual chemical degradation when subject to very high applied voltages thus implying that the number of tests should be strictly limited. We therefore strongly advise against repeated high voltage isolation testing, but if it is absolutely required, that the voltage be reduced by 20% from specified test voltage. Furthermore, the high voltage isolation capability after reflow solder process should be evaluated as it is applied on system.

Characteristic Curves

All test conditions are at 25°C. The figures are identical for MKWI80-24S05

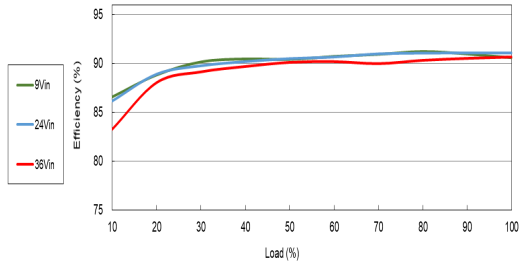

Efficiency Versus Output Current

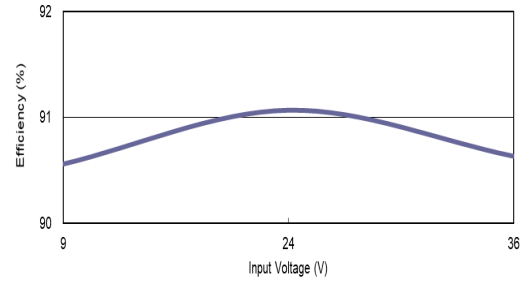

Efficiency Versus Input Voltage Full Load

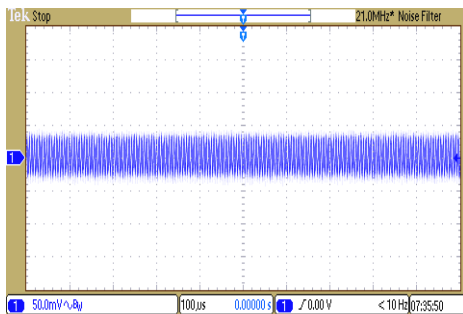

Typical Output Ripple and Noise
 $V_{in}=V_{in\ nom}$; Full Load

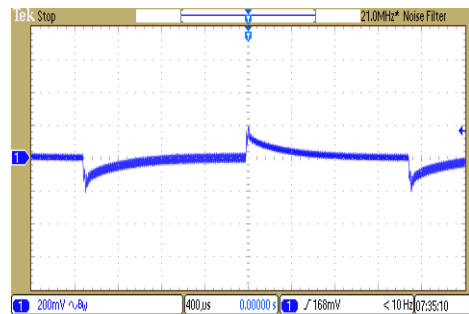

Transient Response to Dynamic Load Change
from 100% to 75% of Full Load; $V_{in}=V_{in\ nom}$

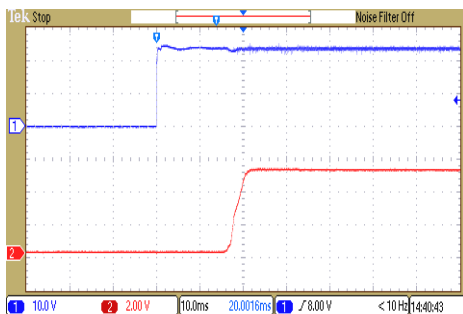

Typical Input Start-Up and Output Rise Characteristic
 $V_{in}=V_{in\ nom}$; Full Load

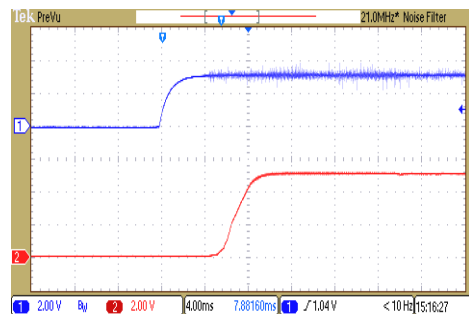

ON/OFF Voltage Start-Up and Output Rise Characteristic
 $V_{in}=V_{in\ nom}$; Full Load

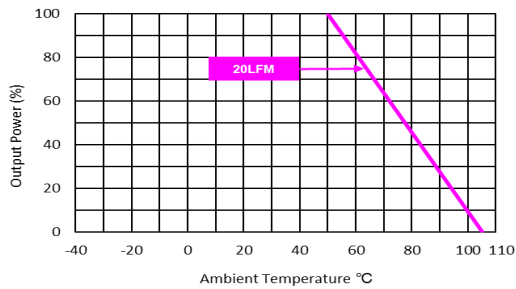

Derating Output Current Versus Ambient Temperature
 $V_{in}=V_{in\ nom}$ (without heatsink)

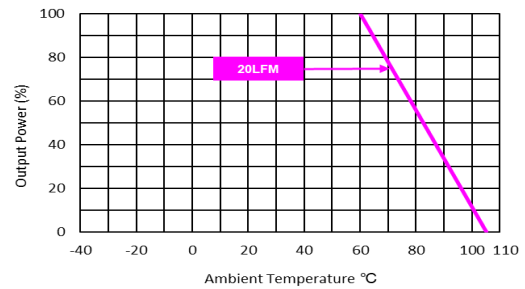

Derating Output Current Versus Ambient Temperature
 $V_{in}=V_{in\ nom}$ (with heatsink)

Characteristic Curves

All test conditions are at 25°C. The figures are identical for MKWI80-24S12

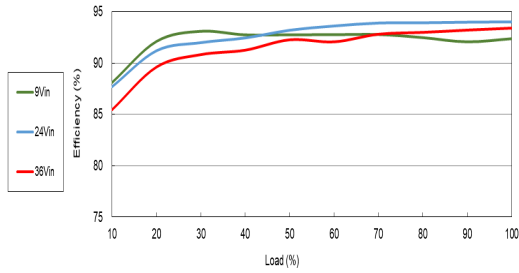

Efficiency Versus Output Current

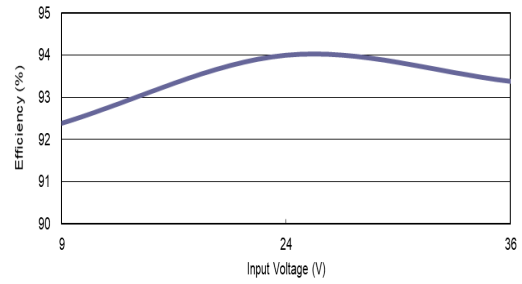

Efficiency Versus Input Voltage Full Load

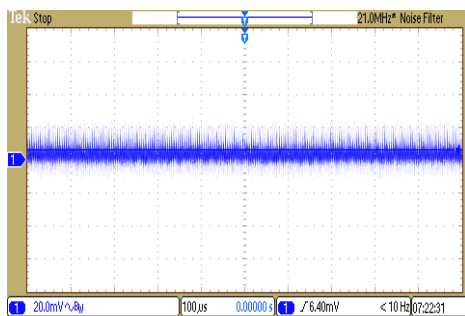

Typical Output Ripple and Noise
 $V_{in}=V_{in\ nom}$; Full Load



Transient Response to Dynamic Load Change
from 100% to 75% of Full Load; $V_{in}=V_{in\ nom}$

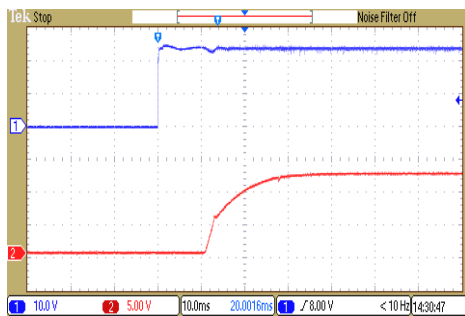

Typical Input Start-Up and Output Rise Characteristic
 $V_{in}=V_{in\ nom}$; Full Load

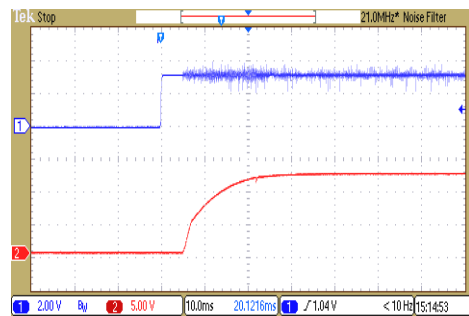

ON/OFF Voltage Start-Up and Output Rise Characteristic
 $V_{in}=V_{in\ nom}$; Full Load

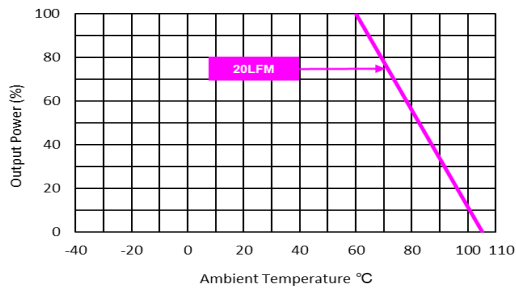

Derating Output Current Versus Ambient Temperature
 $V_{in}=V_{in\ nom}$ (without heatsink)

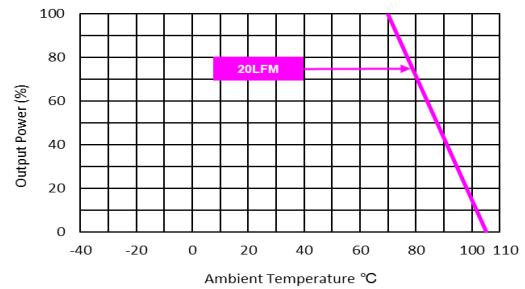

Derating Output Current Versus Ambient Temperature
 $V_{in}=V_{in\ nom}$ (with heatsink)

Characteristic Curves

All test conditions are at 25°C The figures are identical for MKWI80-24S15

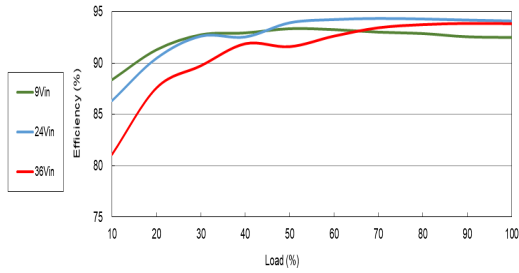

Efficiency Versus Output Current

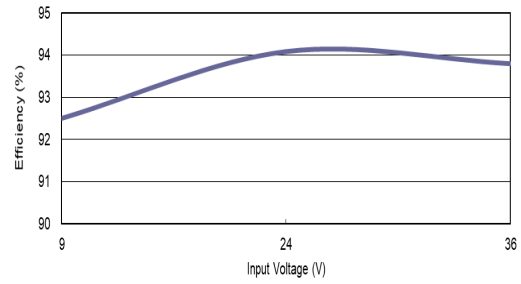

Efficiency Versus Input Voltage Full Load

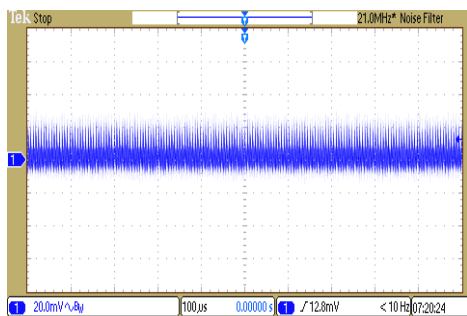

Typical Output Ripple and Noise
 $V_{in}=V_{in\ nom}$; Full Load

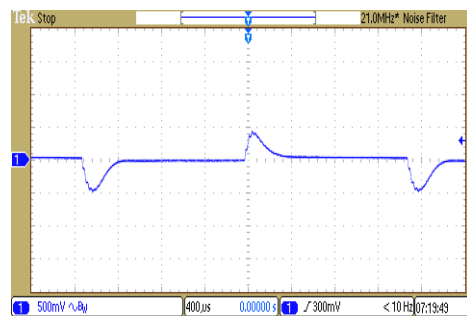

Transient Response to Dynamic Load Change
from 100% to 75% of Full Load; $V_{in}=V_{in\ nom}$

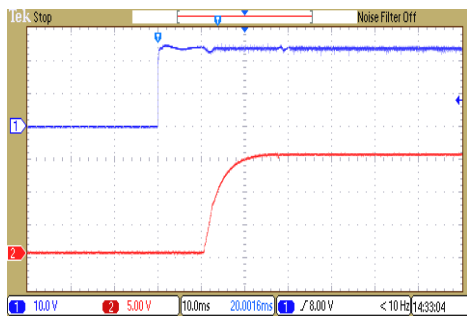

Typical Input Start-Up and Output Rise Characteristic
 $V_{in}=V_{in\ nom}$; Full Load

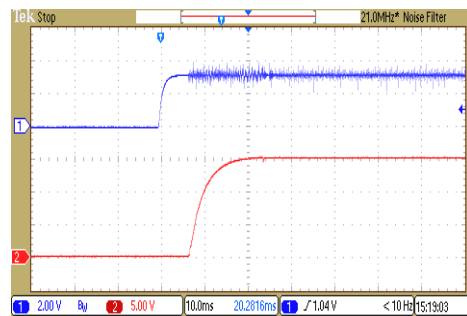

ON/OFF Voltage Start-Up and Output Rise Characteristic
 $V_{in}=V_{in\ nom}$; Full Load

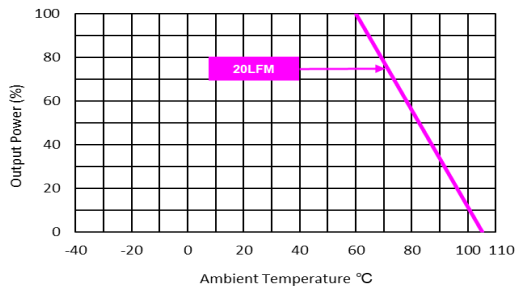

Derating Output Current Versus Ambient Temperature
 $V_{in}=V_{in\ nom}$ (without heatsink)

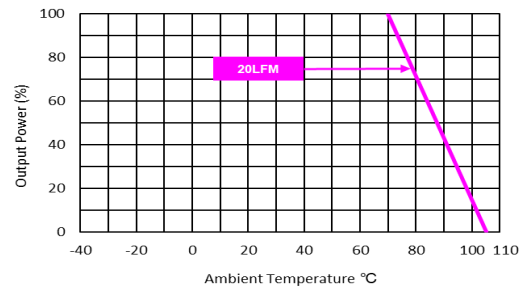

Derating Output Current Versus Ambient Temperature
 $V_{in}=V_{in\ nom}$ (with heatsink)

Characteristic Curves

All test conditions are at 25°C. The figures are identical for MKWI80-24S24

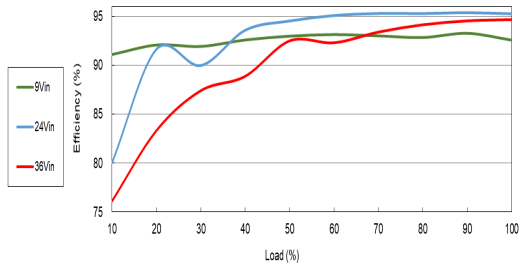

Efficiency Versus Output Current

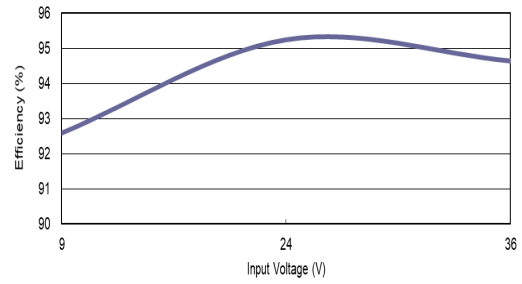

Efficiency Versus Input Voltage Full Load

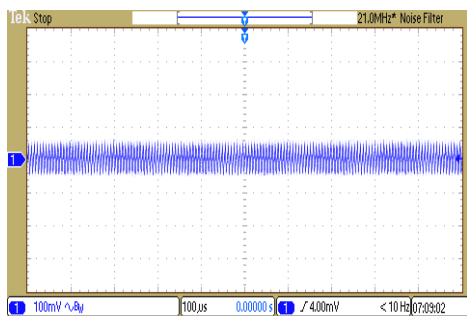

Typical Output Ripple and Noise
 $V_{in}=V_{in\ nom}$; Full Load

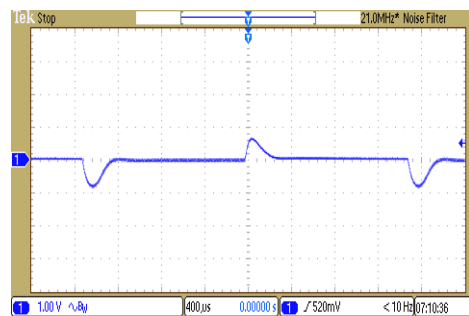

Transient Response to Dynamic Load Change
from 100% to 75% of Full Load; $V_{in}=V_{in\ nom}$

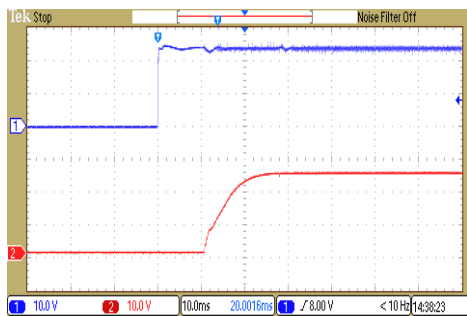

Typical Input Start-Up and Output Rise Characteristic
 $V_{in}=V_{in\ nom}$; Full Load

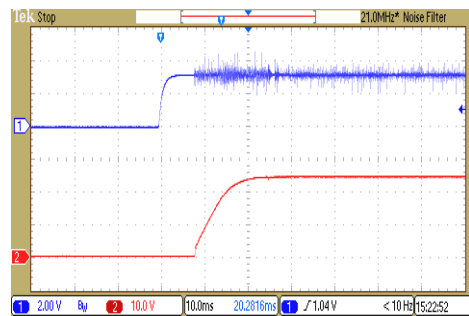

ON/OFF Voltage Start-Up and Output Rise Characteristic
 $V_{in}=V_{in\ nom}$; Full Load

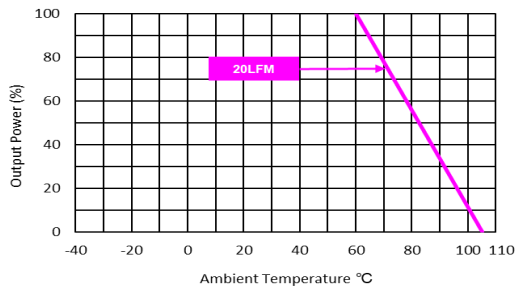

Derating Output Current Versus Ambient Temperature
 $V_{in}=V_{in\ nom}$ (without heatsink)

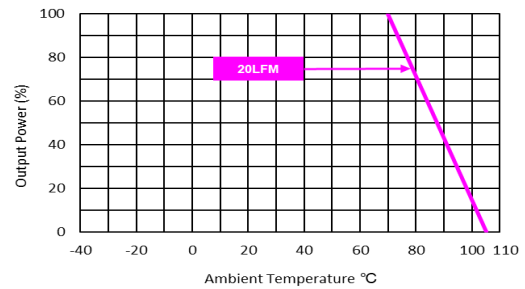

Derating Output Current Versus Ambient Temperature
 $V_{in}=V_{in\ nom}$ (with heatsink)

Characteristic Curves

All test conditions are at 25°C. The figures are identical for MKWI80-24S48

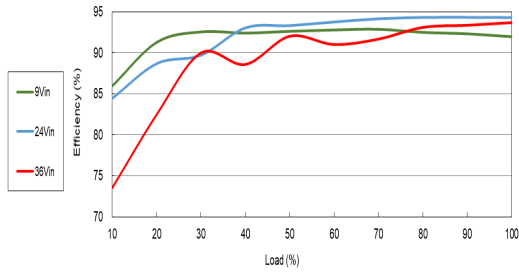

Efficiency Versus Output Current

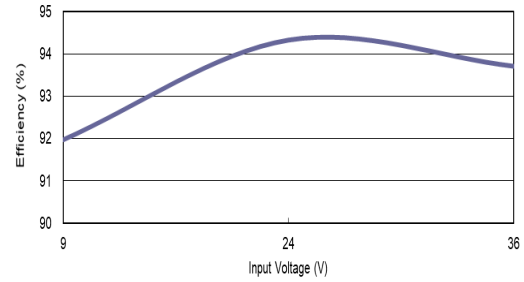

Efficiency Versus Input Voltage Full Load

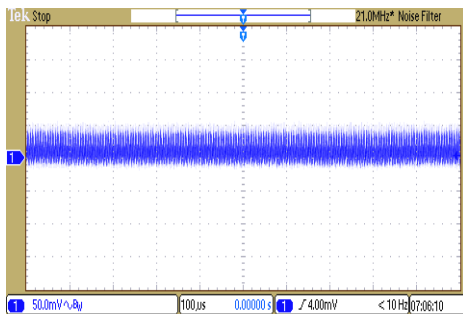

Typical Output Ripple and Noise
 $V_{in}=V_{in\ nom}$; Full Load

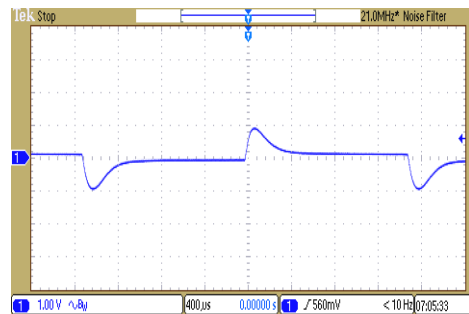

Transient Response to Dynamic Load Change
from 100% to 75% of Full Load; $V_{in}=V_{in\ nom}$

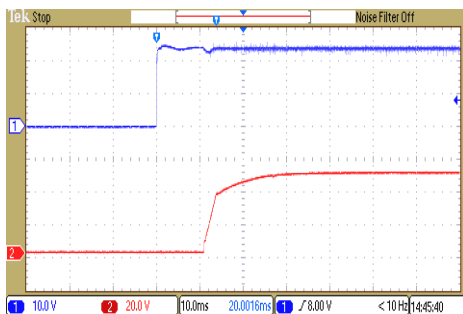

Typical Input Start-Up and Output Rise Characteristic
 $V_{in}=V_{in\ nom}$; Full Load

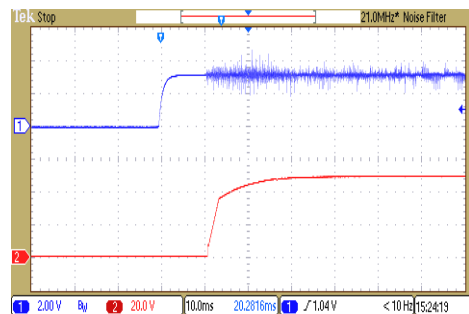

ON/OFF Voltage Start-Up and Output Rise Characteristic
 $V_{in}=V_{in\ nom}$; Full Load

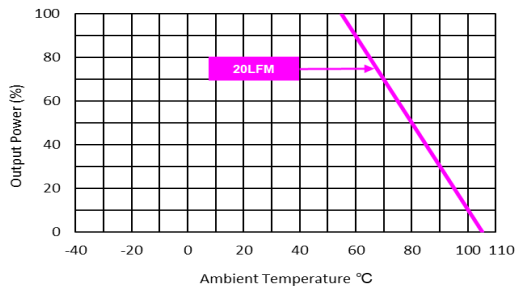

Derating Output Current Versus Ambient Temperature
 $V_{in}=V_{in\ nom}$ (without heatsink)

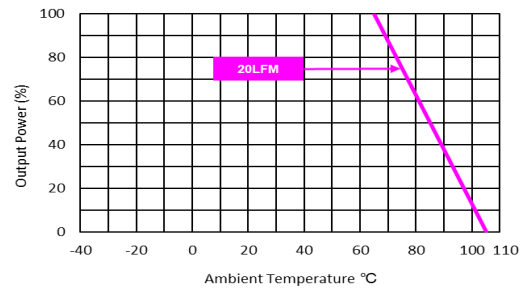

Derating Output Current Versus Ambient Temperature
 $V_{in}=V_{in\ nom}$ (with heatsink)

Characteristic Curves

All test conditions are at 25°C The figures are identical for MKWI80-24S54

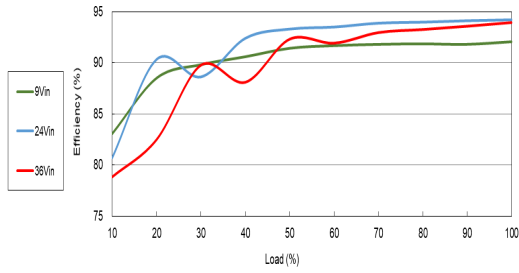

Efficiency Versus Output Current

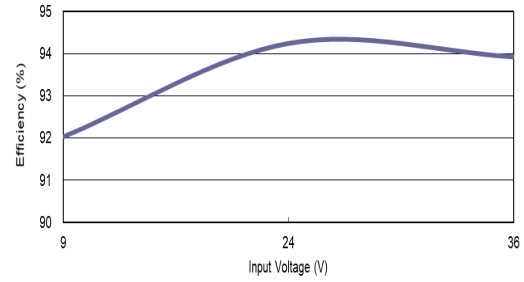

Efficiency Versus Input Voltage Full Load

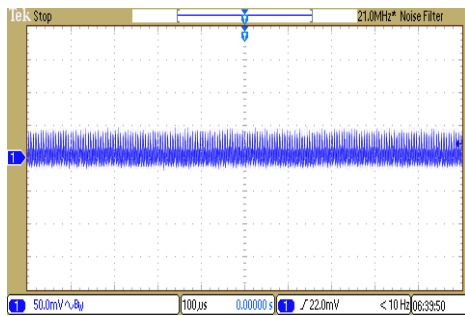

Typical Output Ripple and Noise
 $V_{in}=V_{in\ nom}$; Full Load

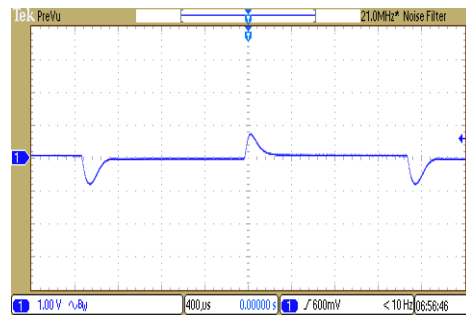

Transient Response to Dynamic Load Change
from 100% to 75% of Full Load; $V_{in}=V_{in\ nom}$

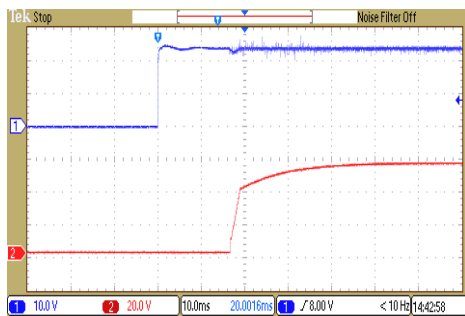

Typical Input Start-Up and Output Rise Characteristic
 $V_{in}=V_{in\ nom}$; Full Load

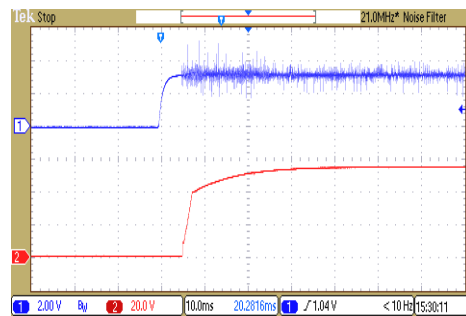

ON/OFF Voltage Start-Up and Output Rise Characteristic
 $V_{in}=V_{in\ nom}$; Full Load

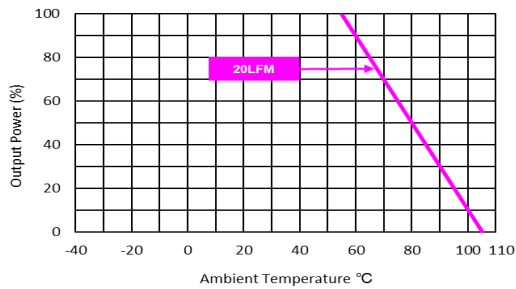

Derating Output Current Versus Ambient Temperature
 $V_{in}=V_{in\ nom}$ (without heatsink)

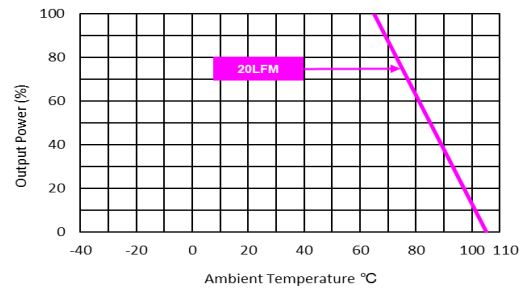

Derating Output Current Versus Ambient Temperature
 $V_{in}=V_{in\ nom}$ (with heatsink)

Characteristic Curves

All test conditions are at 25°C The figures are identical for MKWI80-24D12

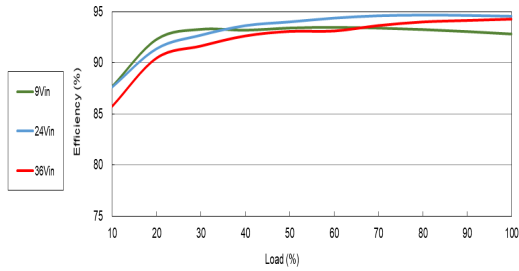

Efficiency Versus Output Current

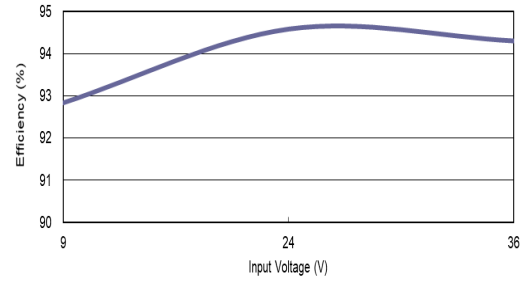

Efficiency Versus Input Voltage Full Load

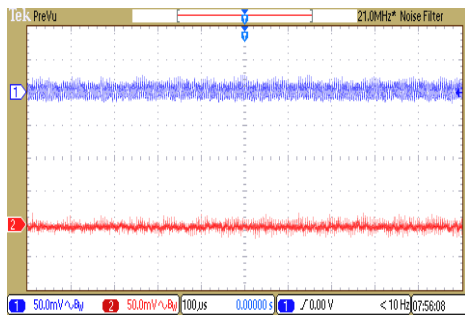

Typical Output Ripple and Noise
 $V_{in}=V_{in\ nom}$; Full Load

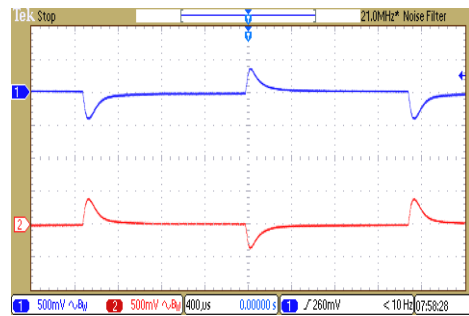

Transient Response to Dynamic Load Change
from 100% to 75% of Full Load ; $V_{in}=V_{in\ nom}$



Typical Input Start-Up and Output Rise Characteristic
 $V_{in}=V_{in\ nom}$; Full Load

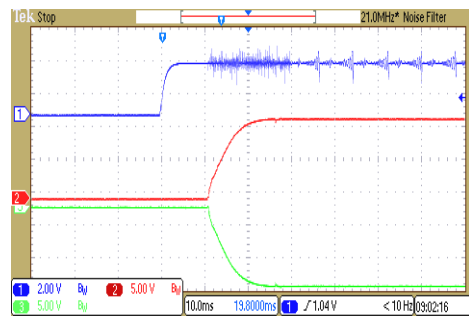

ON/OFF Voltage Start-Up and Output Rise Characteristic
 $V_{in}=V_{in\ nom}$; Full Load

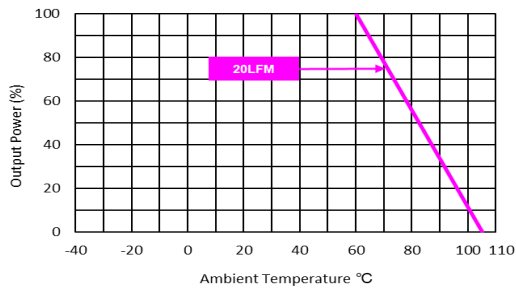

Derating Output Current Versus Ambient Temperature
 $V_{in}=V_{in\ nom}$ (without heatsink)

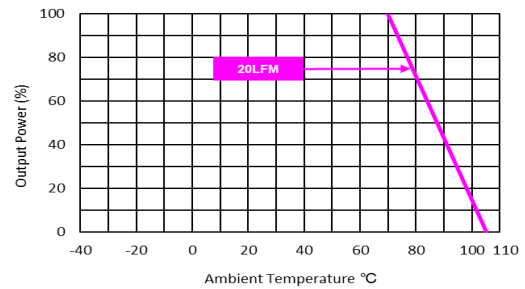

Derating Output Current Versus Ambient Temperature
 $V_{in}=V_{in\ nom}$ (with heatsink)

Characteristic Curves

All test conditions are at 25°C The figures are identical for MKWI80-24D15

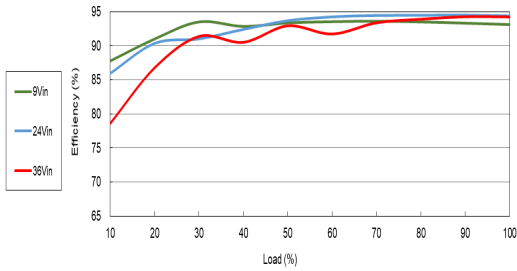

Efficiency Versus Output Current

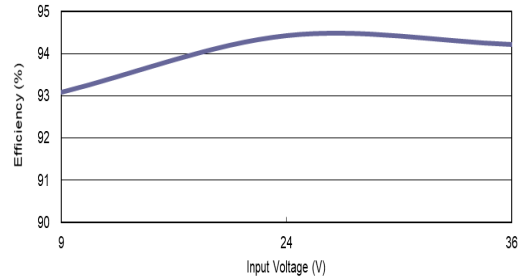

Efficiency Versus Input Voltage Full Load

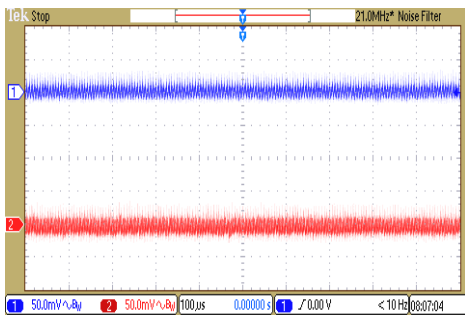

Typical Output Ripple and Noise
 $V_{in}=V_{in\ nom}$; Full Load

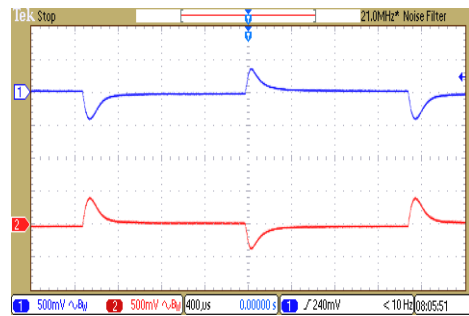

Transient Response to Dynamic Load Change
from 100% to 75% of Full Load ; $V_{in}=V_{in\ nom}$

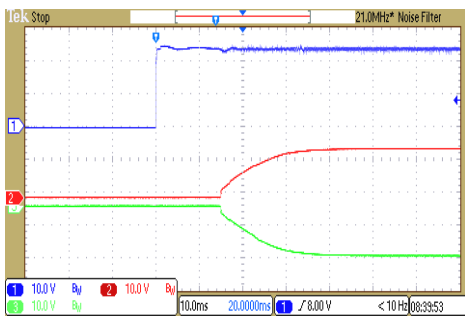

Typical Input Start-Up and Output Rise Characteristic
 $V_{in}=V_{in\ nom}$; Full Load

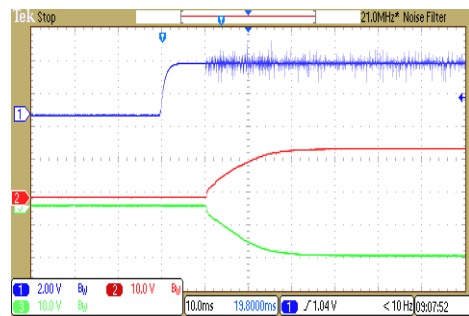

ON/OFF Voltage Start-Up and Output Rise Characteristic
 $V_{in}=V_{in\ nom}$; Full Load

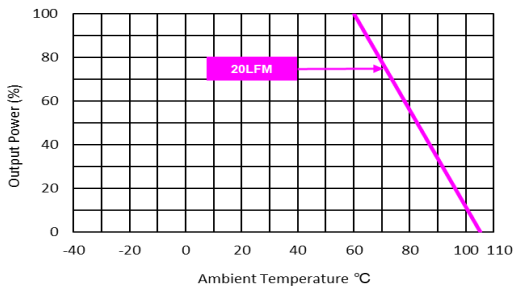

Derating Output Current Versus Ambient Temperature
 $V_{in}=V_{in\ nom}$ (without heatsink)

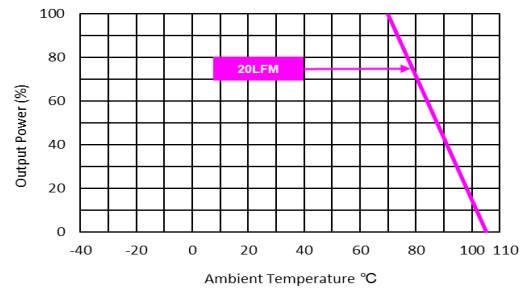

Derating Output Current Versus Ambient Temperature
 $V_{in}=V_{in\ nom}$ (with heatsink)

Characteristic Curves

All test conditions are at 25°C The figures are identical for MKWI80-48S05

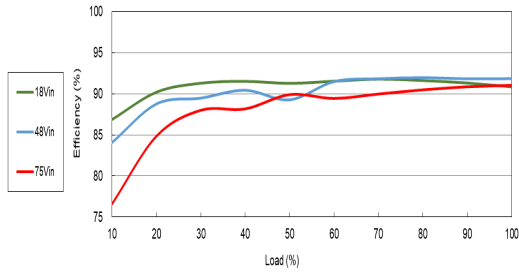

Efficiency Versus Output Current

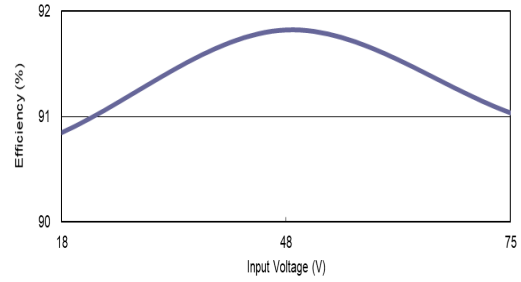

Efficiency Versus Input Voltage Full Load

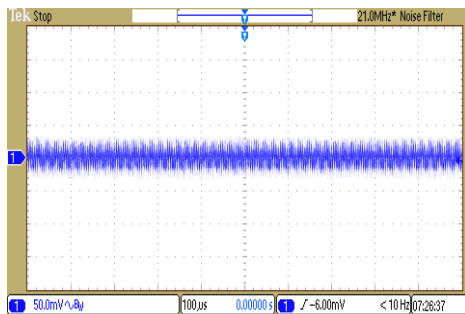

Typical Output Ripple and Noise
 $V_{in}=V_{in\ nom}$; Full Load

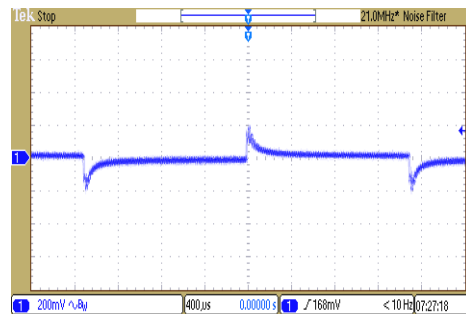

Transient Response to Dynamic Load Change
from 100% to 75% of Full Load; $V_{in}=V_{in\ nom}$

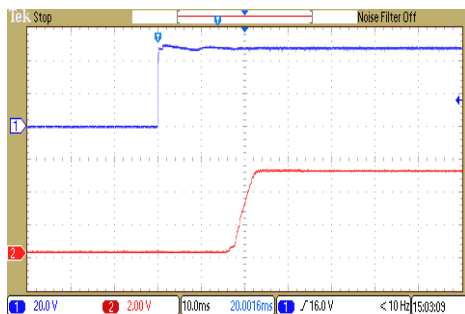

Typical Input Start-Up and Output Rise Characteristic
 $V_{in}=V_{in\ nom}$; Full Load

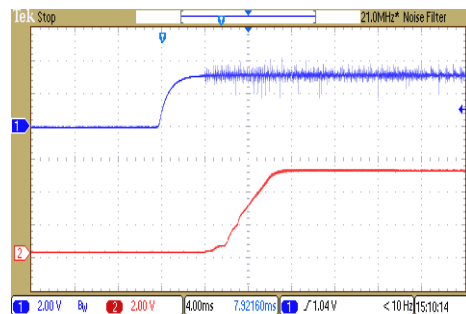

ON/OFF Voltage Start-Up and Output Rise Characteristic
 $V_{in}=V_{in\ nom}$; Full Load

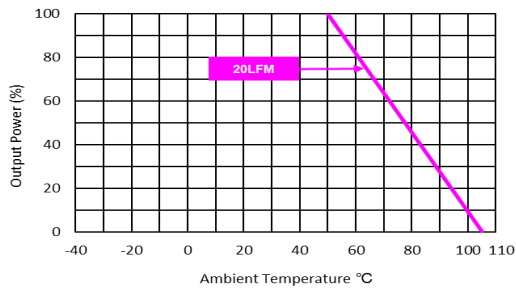

Derating Output Current Versus Ambient Temperature
 $V_{in}=V_{in\ nom}$ (without heatsink)

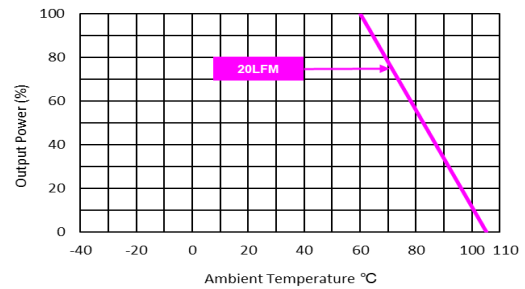

Derating Output Current Versus Ambient Temperature
 $V_{in}=V_{in\ nom}$ (with heatsink)

Characteristic Curves

All test conditions are at 25°C. The figures are identical for MKWI80-48S12

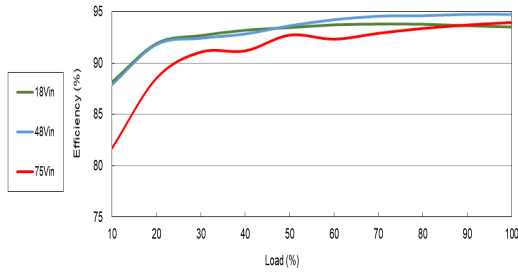

Efficiency Versus Output Current

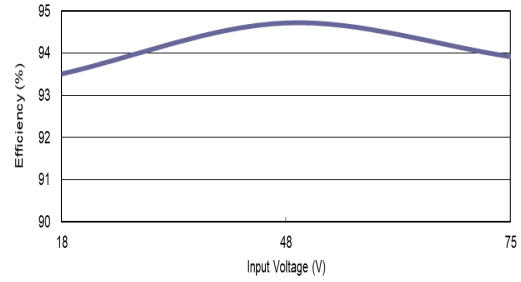

Efficiency Versus Input Voltage
Full Load

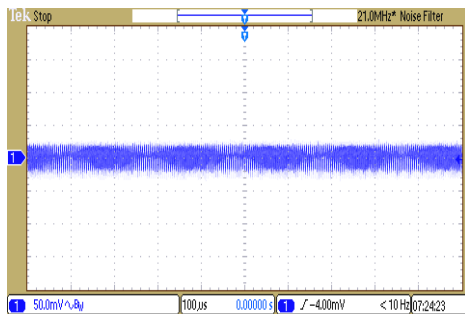

Typical Output Ripple and Noise
 $V_{in}=V_{in\ nom}$; Full Load

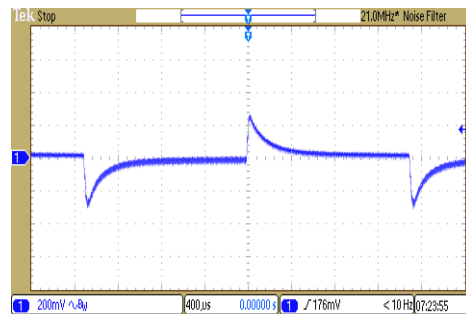

Transient Response to Dynamic Load Change
from 100% to 75% of Full Load; $V_{in}=V_{in\ nom}$

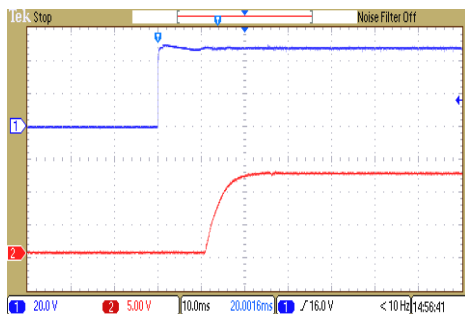

Typical Input Start-Up and Output Rise Characteristic
 $V_{in}=V_{in\ nom}$; Full Load

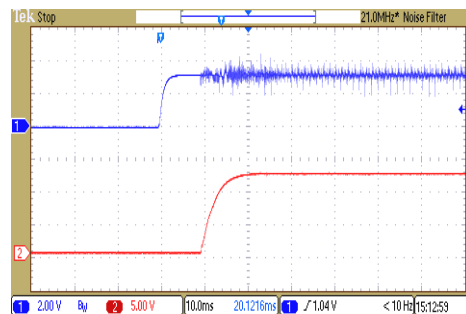

ON/OFF Voltage Start-Up and Output Rise Characteristic
 $V_{in}=V_{in\ nom}$; Full Load

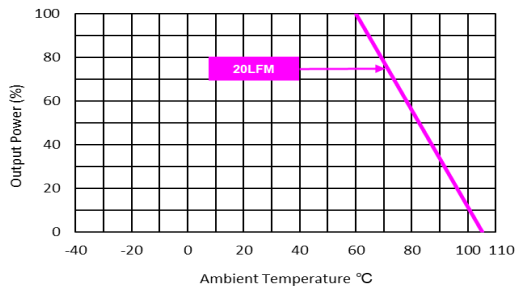

Derating Output Current Versus Ambient Temperature
 $V_{in}=V_{in\ nom}$ (without heatsink)

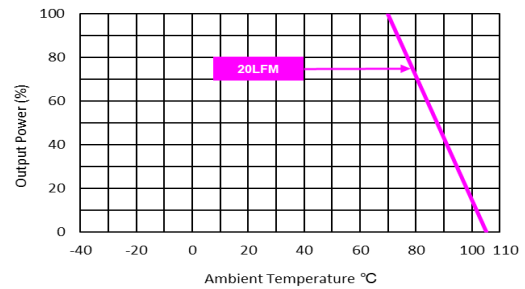

Derating Output Current Versus Ambient Temperature
 $V_{in}=V_{in\ nom}$ (with heatsink)

Characteristic Curves

All test conditions are at 25°C. The figures are identical for MKWI80-48S15

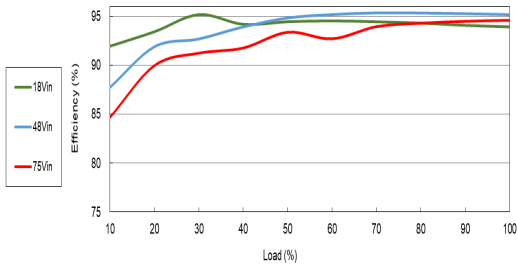

Efficiency Versus Output Current

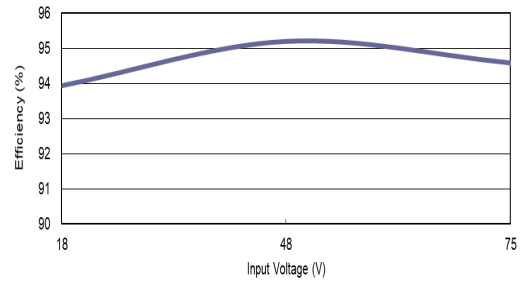

Efficiency Versus Input Voltage Full Load

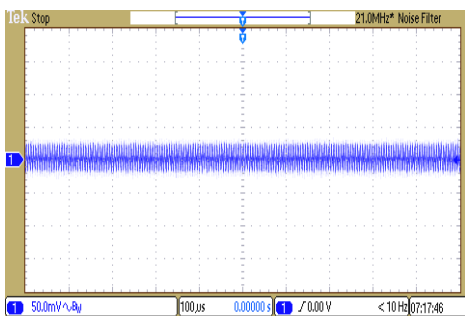

Typical Output Ripple and Noise
 $V_{in}=V_{in\ nom}$; Full Load

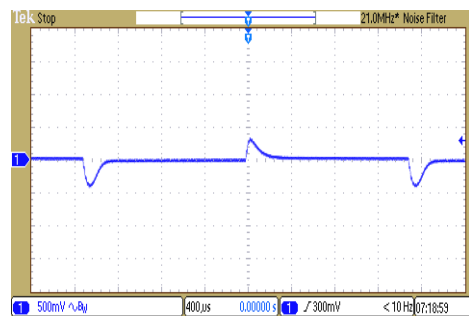

Transient Response to Dynamic Load Change
from 100% to 75% of Full Load; $V_{in}=V_{in\ nom}$

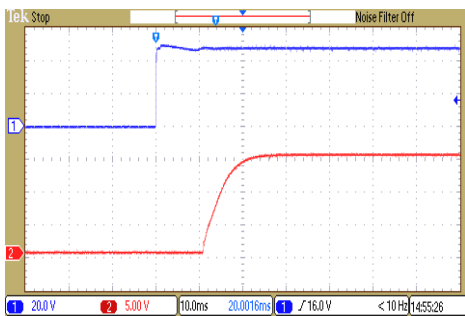

Typical Input Start-Up and Output Rise Characteristic
 $V_{in}=V_{in\ nom}$; Full Load

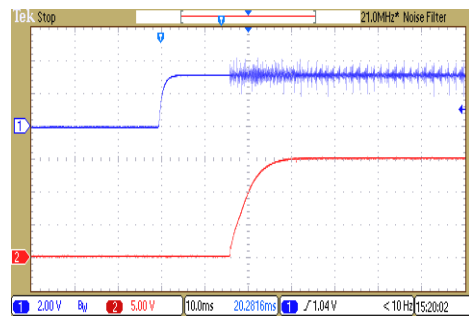

ON/OFF Voltage Start-Up and Output Rise Characteristic
 $V_{in}=V_{in\ nom}$; Full Load

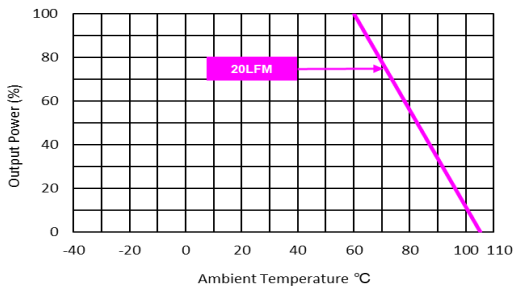

Derating Output Current Versus Ambient Temperature
 $V_{in}=V_{in\ nom}$ (without heatsink)

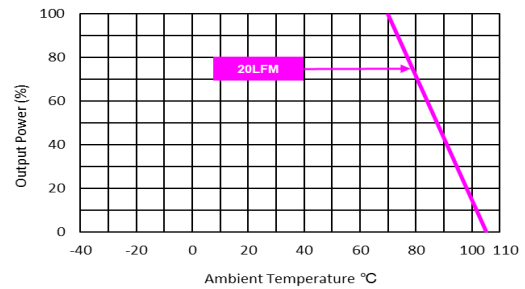

Derating Output Current Versus Ambient Temperature
 $V_{in}=V_{in\ nom}$ (with heatsink)

Characteristic Curves

All test conditions are at 25°C. The figures are identical for MKWI80-48S24

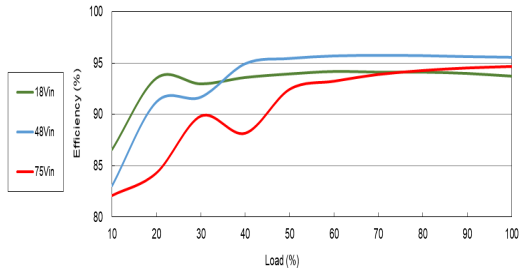

Efficiency Versus Output Current

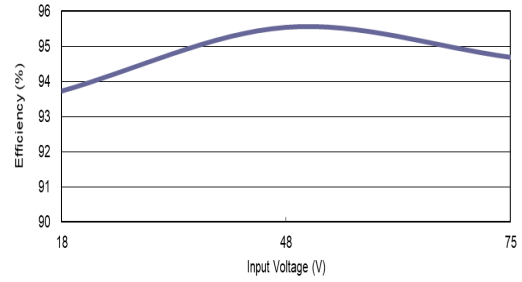

Efficiency Versus Input Voltage Full Load

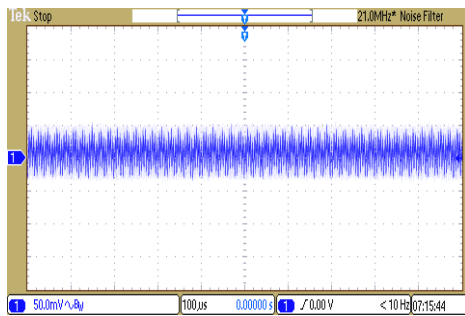

Typical Output Ripple and Noise
 $V_{in}=V_{in\ nom}$; Full Load

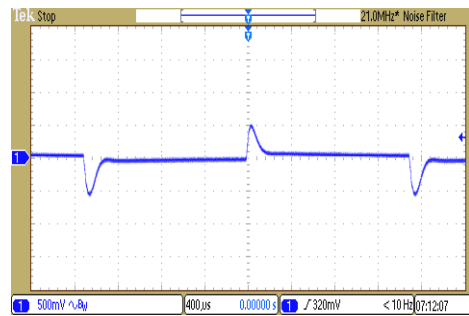

Transient Response to Dynamic Load Change
from 100% to 75% of Full Load; $V_{in}=V_{in\ nom}$

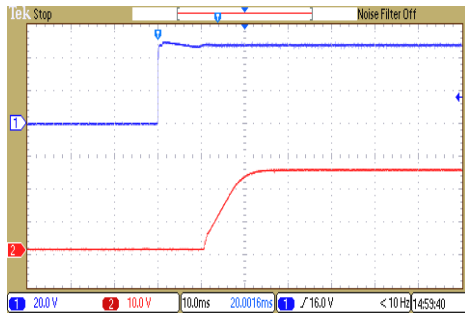

Typical Input Start-Up and Output Rise Characteristic
 $V_{in}=V_{in\ nom}$; Full Load

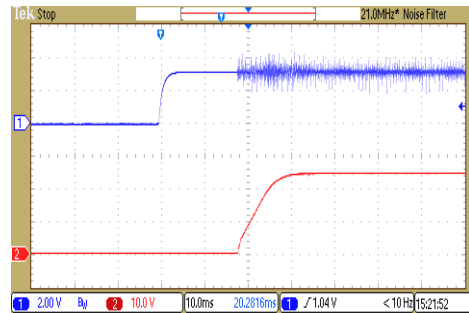

ON/OFF Voltage Start-Up and Output Rise Characteristic
 $V_{in}=V_{in\ nom}$; Full Load

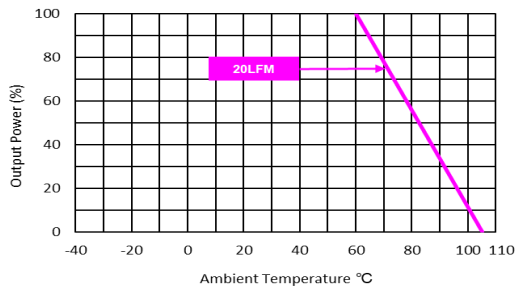

Derating Output Current Versus Ambient Temperature
 $V_{in}=V_{in\ nom}$ (without heatsink)

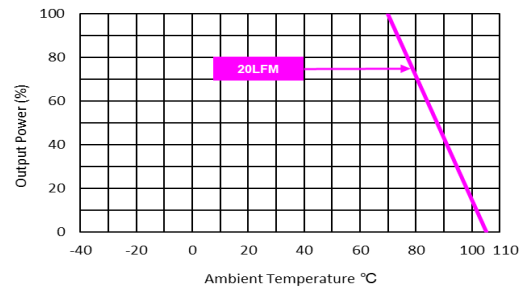

Derating Output Current Versus Ambient Temperature
 $V_{in}=V_{in\ nom}$ (with heatsink)

Characteristic Curves

All test conditions are at 25°C. The figures are identical for MKWI80-48S48

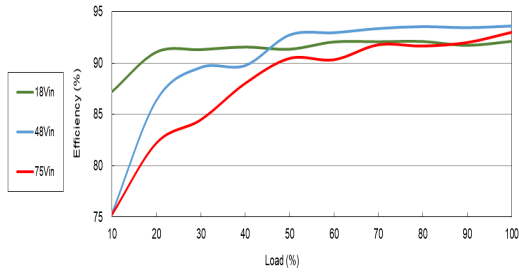

Efficiency Versus Output Current

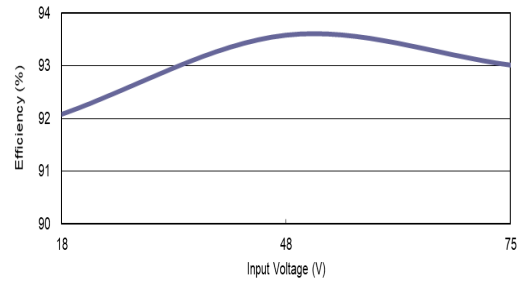

Efficiency Versus Input Voltage Full Load

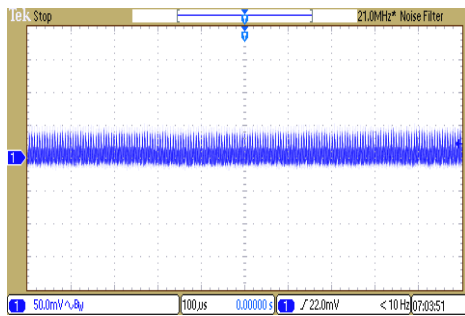

Typical Output Ripple and Noise
 $V_{in}=V_{in\ nom}$; Full Load



Transient Response to Dynamic Load Change
from 100% to 75% of Full Load; $V_{in}=V_{in\ nom}$

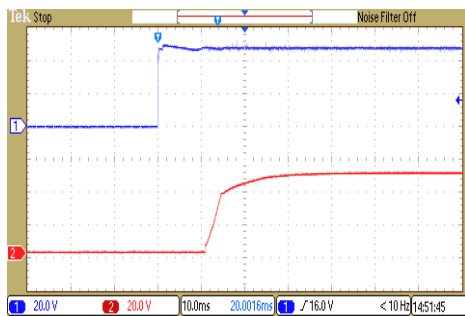

Typical Input Start-Up and Output Rise Characteristic
 $V_{in}=V_{in\ nom}$; Full Load

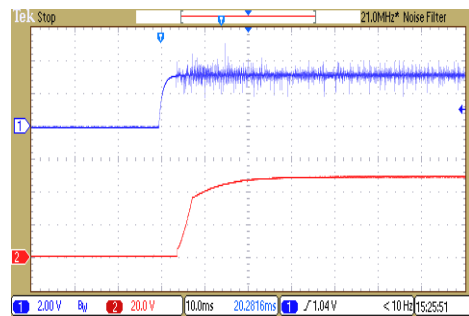

ON/OFF Voltage Start-Up and Output Rise Characteristic
 $V_{in}=V_{in\ nom}$; Full Load

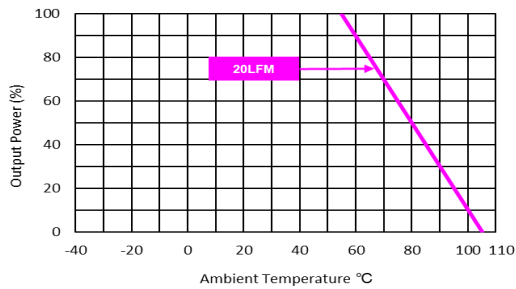

Derating Output Current Versus Ambient Temperature
 $V_{in}=V_{in\ nom}$ (without heatsink)

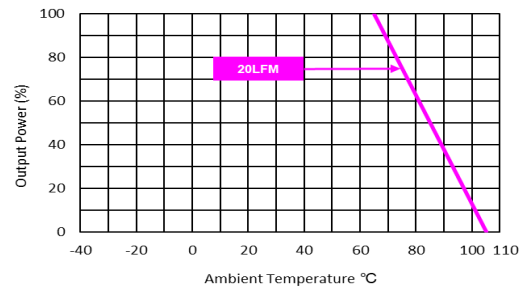

Derating Output Current Versus Ambient Temperature
 $V_{in}=V_{in\ nom}$ (with heatsink)

Characteristic Curves

All test conditions are at 25°C. The figures are identical for MKWI80-48S54

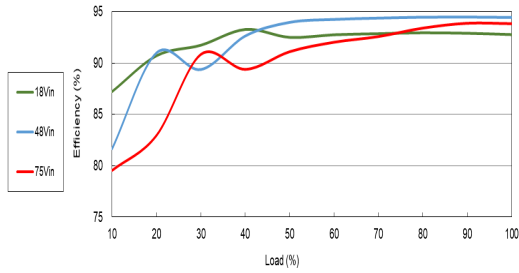

Efficiency Versus Output Current

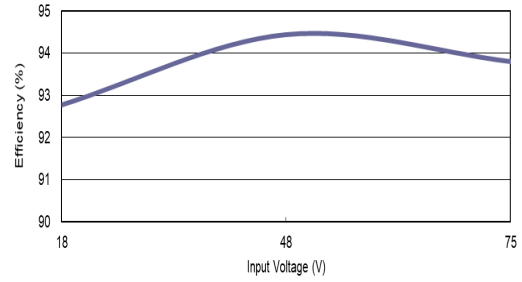

Efficiency Versus Input Voltage Full Load

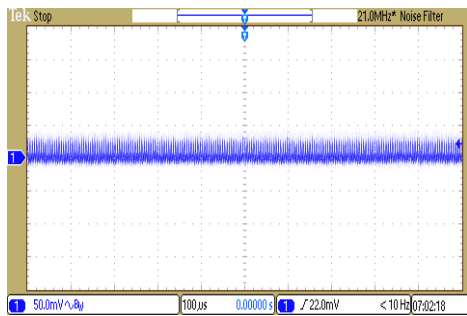

Typical Output Ripple and Noise
 $V_{in}=V_{in\ nom}$; Full Load

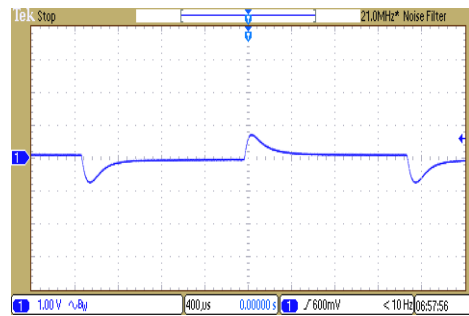

Transient Response to Dynamic Load Change
from 100% to 75% of Full Load; $V_{in}=V_{in\ nom}$

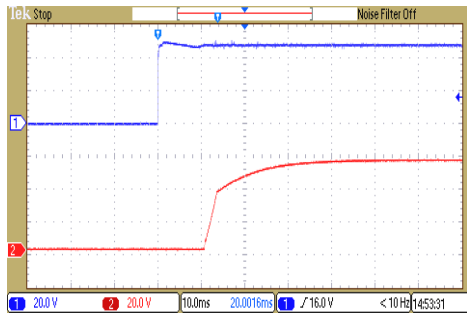

Typical Input Start-Up and Output Rise Characteristic
 $V_{in}=V_{in\ nom}$; Full Load

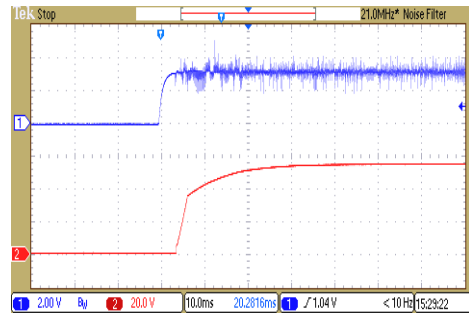

ON/OFF Voltage Start-Up and Output Rise Characteristic
 $V_{in}=V_{in\ nom}$; Full Load

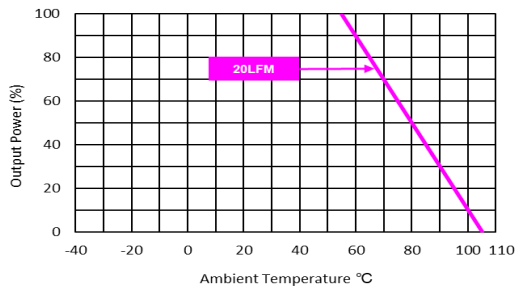

Derating Output Current Versus Ambient Temperature
 $V_{in}=V_{in\ nom}$ (without heatsink)

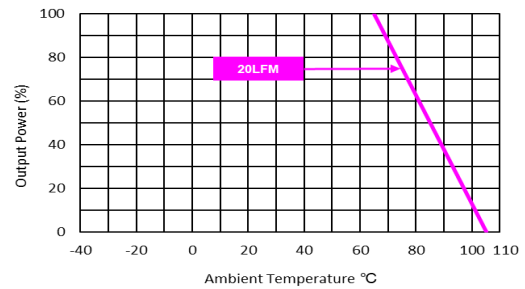

Derating Output Current Versus Ambient Temperature
 $V_{in}=V_{in\ nom}$ (with heatsink)

Characteristic Curves

All test conditions are at 25°C. The figures are identical for MKWI80-48D12

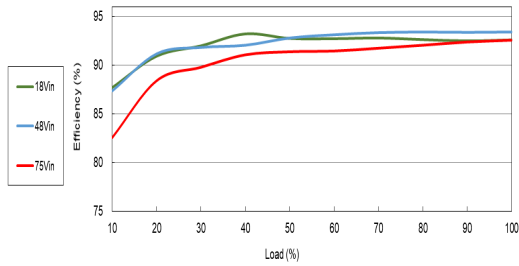

Efficiency Versus Output Current

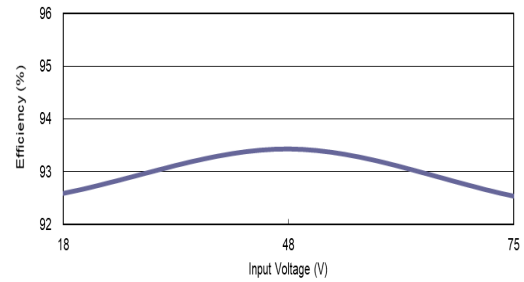

Efficiency Versus Input Voltage Full Load

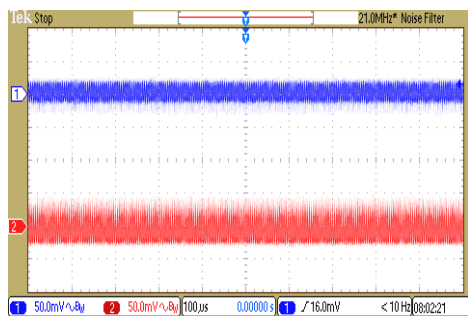

Typical Output Ripple and Noise
 $V_{in}=V_{in\ nom}$; Full Load

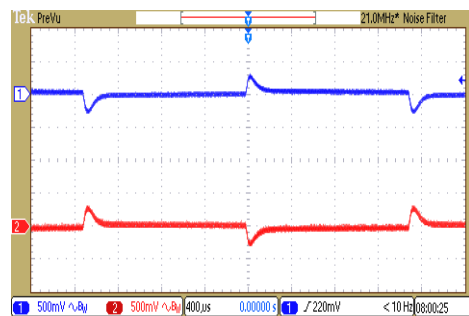

Transient Response to Dynamic Load Change
from 100% to 75% of Full Load; $V_{in}=V_{in\ nom}$



Typical Input Start-Up and Output Rise Characteristic
 $V_{in}=V_{in\ nom}$; Full Load

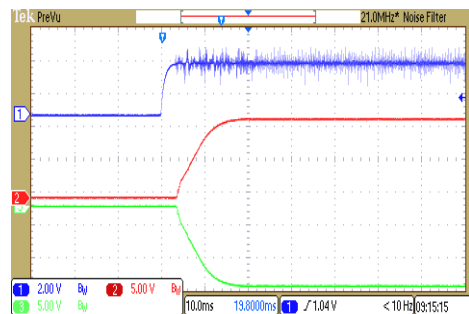

ON/OFF Voltage Start-Up and Output Rise Characteristic
 $V_{in}=V_{in\ nom}$; Full Load

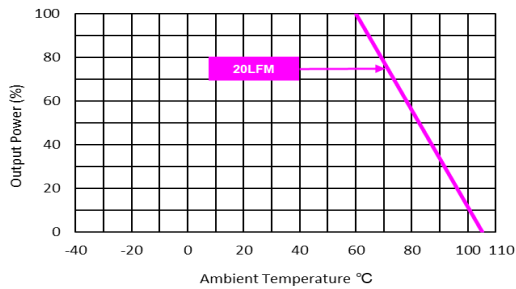

Derating Output Current Versus Ambient Temperature
 $V_{in}=V_{in\ nom}$ (without heatsink)

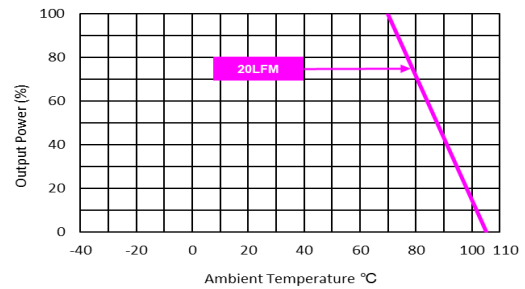

Derating Output Current Versus Ambient Temperature
 $V_{in}=V_{in\ nom}$ (with heatsink)

Characteristic Curves

All test conditions are at 25°C. The figures are identical for MKWI80-48D15

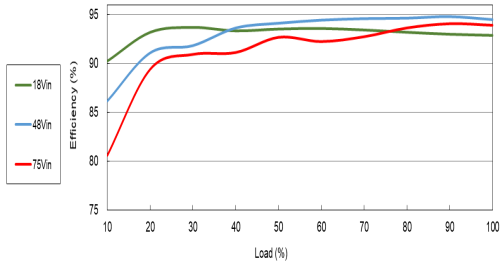

Efficiency Versus Output Current

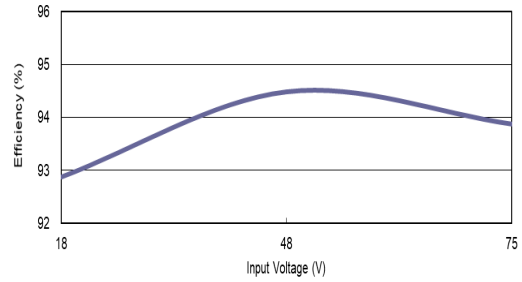

Efficiency Versus Input Voltage Full Load

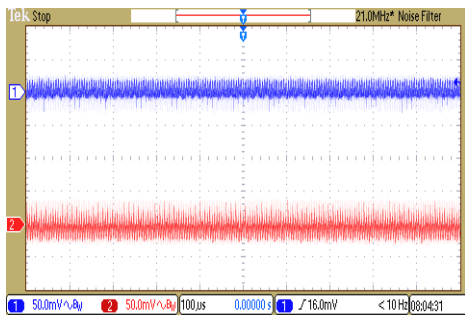

Typical Output Ripple and Noise
 $V_{in}=V_{in\ nom}$; Full Load

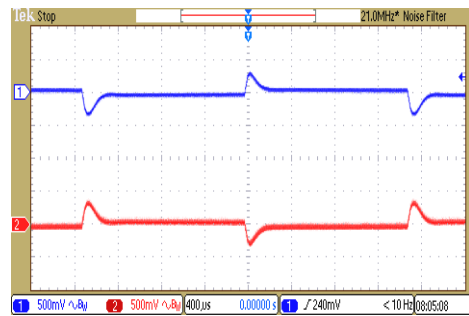

Transient Response to Dynamic Load Change
from 100% to 75% of Full Load; $V_{in}=V_{in\ nom}$



Typical Input Start-Up and Output Rise Characteristic
 $V_{in}=V_{in\ nom}$; Full Load

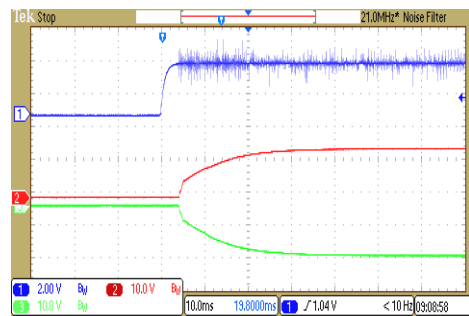

ON/OFF Voltage Start-Up and Output Rise Characteristic
 $V_{in}=V_{in\ nom}$; Full Load

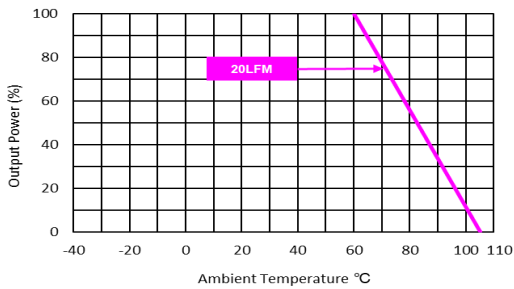

Derating Output Current Versus Ambient Temperature
 $V_{in}=V_{in\ nom}$ (without heatsink)

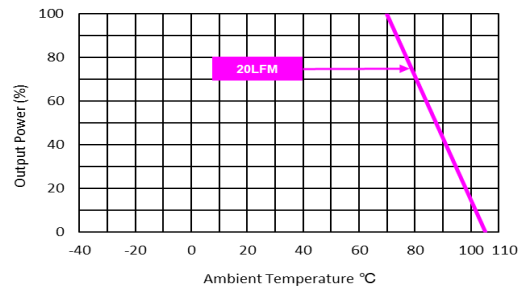

Derating Output Current Versus Ambient Temperature
 $V_{in}=V_{in\ nom}$ (with heatsink)

Recommended Pad Layout

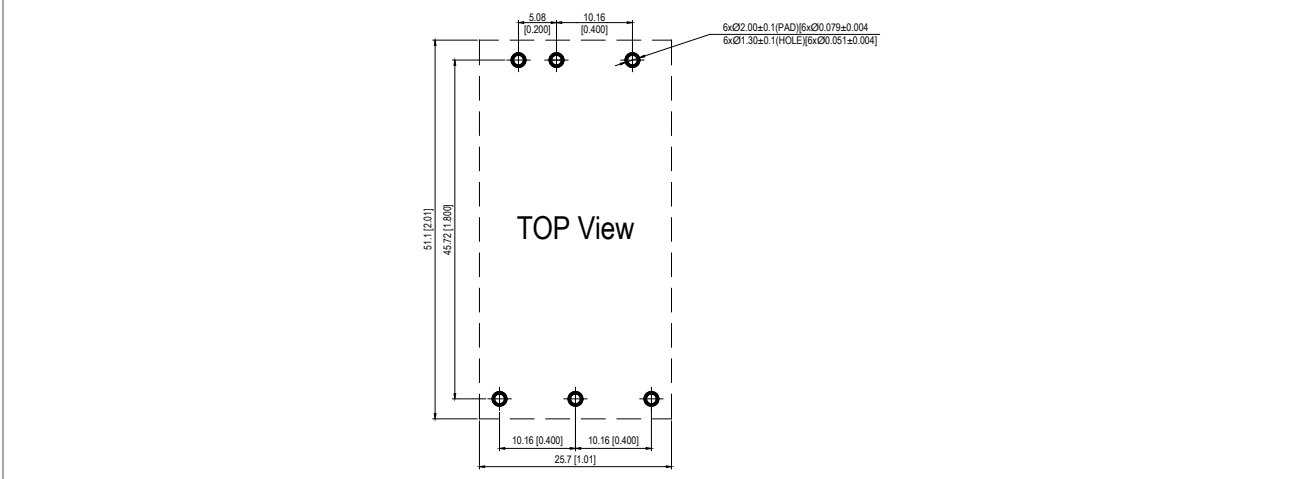

External Output Trimming

Output can be externally trimmed by using the method shown below

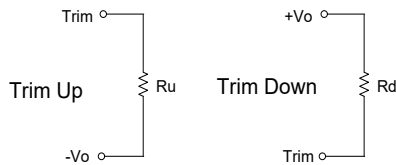

Trim Range (%)	MKWI80-XXS05		MKWI80-XXS12		MKWI80-XXS15		MKWI80-XXS24		MKWI80-XXS48		MKWI80-XXS54	
	Trim down (kΩ)	Trim up (kΩ)	Trim down (kΩ)	Trim up (kΩ)	Trim down (kΩ)	Trim up (kΩ)	Trim down (kΩ)	Trim up (kΩ)	Trim down (kΩ)	Trim up (kΩ)	Trim down (kΩ)	Trim up (kΩ)
1	138.88	106.87	413.55	351.00	530.73	422.77	598.66	487.14	1,194.43	920.37	3,000.15	748.65
2	62.41	47.76	184.55	157.50	238.61	189.89	267.78	218.02	540.12	414.68	1,396.97	291.83
3	36.92	28.06	108.22	93.00	141.24	112.26	157.49	128.31	322.01	246.12	862.58	139.55
4	24.18	18.21	70.05	60.75	92.56	73.44	102.34	83.46	212.96	161.84	595.39	63.41
5	16.53	12.30	47.15	41.40	63.35	50.15	69.25	56.55	147.53	111.27	435.07	17.73
6	11.44	8.36	31.88	28.50	43.87	34.63	47.19	38.61	103.91	77.56	328.19	---
7	7.79	5.55	20.98	19.29	29.96	23.54	31.44	25.79	72.75	53.48	251.85	---
8	5.06	3.44	12.80	12.37	19.53	15.22	19.62	16.18	49.38	35.42	194.59	---
9	2.94	1.79	6.44	7.00	11.41	8.75	10.43	8.70	31.20	21.37	150.06	---
10	1.24	0.48	1.35	2.70	4.92	3.58	3.08	2.72	16.66	10.14	114.43	---
11	---	---	---	---	---	---	---	---	---	---	85.29	---
12	---	---	---	---	---	---	---	---	---	---	61.00	---
13	---	---	---	---	---	---	---	---	---	---	40.44	---
14	---	---	---	---	---	---	---	---	---	---	22.82	---
15	---	---	---	---	---	---	---	---	---	---	7.56	---

Test Setup

Input Reflected-Ripple Current Test Setup

Input reflected-ripple current is measured with an inductor L_{in} (4.7 μ H) and C_{in} (220 μ F, ESR < 1.0 Ω at 100 kHz) to simulate source impedance. Capacitor C_{in} offsets possible battery impedance. Current ripple is measured at the input terminals of the module, measurement bandwidth is 0-500 kHz.

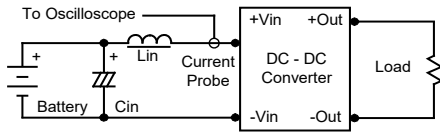

Peak-to-Peak Output Noise Measurement Test

Use external ceramic capacitor, please refer to the descriptions in the "Ripple & Noise" section on page 2. Scope measurement should be made by using a BNC socket, measurement bandwidth is 0-20 MHz. Position the load between 50 mm and 75 mm from the DC-DC Converter.

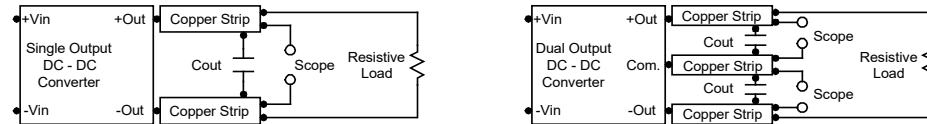

Technical Notes

Remote On/Off

Positive logic remote on/off turns the module on during a logic high voltage on the remote on/off pin, and off during a logic low. To turn the power module on and off, the user must supply a switch to control the voltage between the on/off terminal and the -Vin terminal.

The switch can be an open collector or equivalent. A logic low is 0V to 1.2V. A logic high is 3.5V to 12V. The maximum sink current at on/off terminal during a logic low is -500 μ A. The maximum allowable leakage current of the switch at on/off terminal (3.5 to 12V) is 500 μ A.

Overload Protection

To provide protection in a fault (output overload) condition, the unit is equipped with internal current limiting circuitry and can endure current limiting for an unlimited duration. At the point of current-limit inception, the unit shifts from voltage control to current control. The unit operates normally once the output current is brought back into its specified range.

Input Source Impedance

The power module should be connected to a low ac-impedance input source. Highly inductive source impedances can affect the stability of the power module.

In applications where power is supplied over long lines and output loading is high, it may be necessary to use a capacitor at the input to ensure startup.

Capacitor mounted close to the power module helps ensure stability of the unit, it is recommended to use a good quality low Equivalent Series Resistance (ESR < 1.0 Ω at 100 kHz) capacitor of a 68 μ F for the 24V and 48V devices.

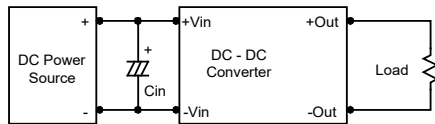

Output Ripple Reduction

A good quality low ESR capacitor placed as close as practicable across the load will give the best ripple and noise performance. To reduce output ripple, it is recommended to use 22 μ F capacitors at the output.

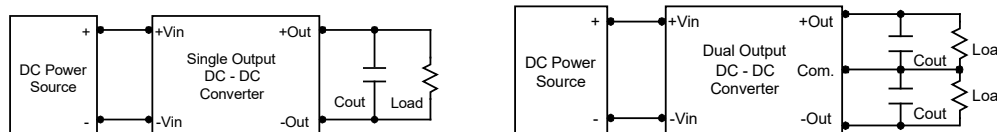

Maximum Capacitive Load

The MKWI80 series has limitation of maximum connected capacitance at the output. The power module may be operated in current limiting mode during start-up, affecting the ramp-up and the startup time. The maximum capacitance can be found in the data sheet.

Thermal Considerations

Many conditions affect the thermal performance of the power module, such as orientation, airflow over the module and board spacing. To avoid exceeding the maximum temperature rating of the components inside the power module, the case temperature must be kept below 105 $^{\circ}$ C. The derating curves are determined from measurements obtained in a test setup.

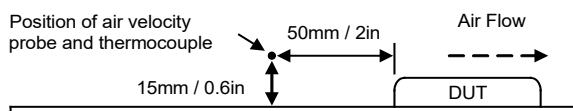

Remote ON/OFF Implementation

The positive logic remote ON/OFF control circuit is included. Turns the module ON during logic High on the ON/Off pin and turns OFF during logic Low. The ON/OFF input signal (Von/off) that referenced to GND. If not using the remote on/off feature, please open circuit between on/off pin and -Vin pin to turn the module on.

Remote ON/OFF implementation

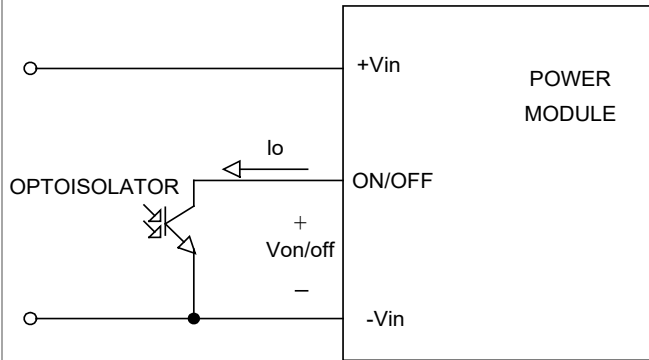

Isolated-Closure Remote ON/OFF

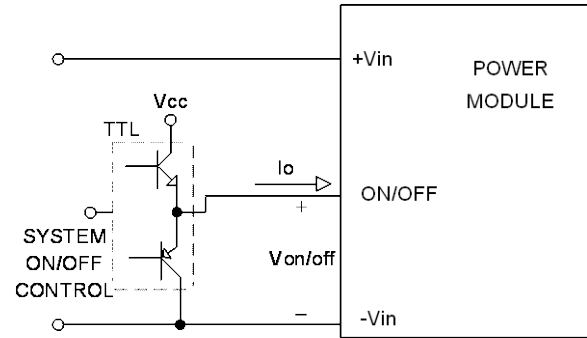

Level Control Using TTL Output

Packaging Information

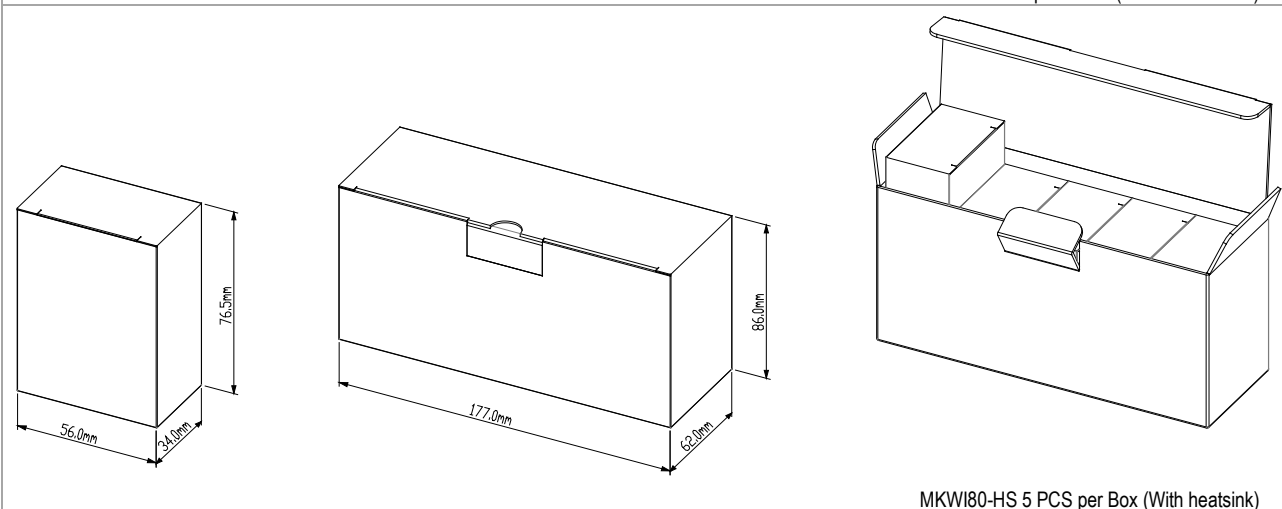
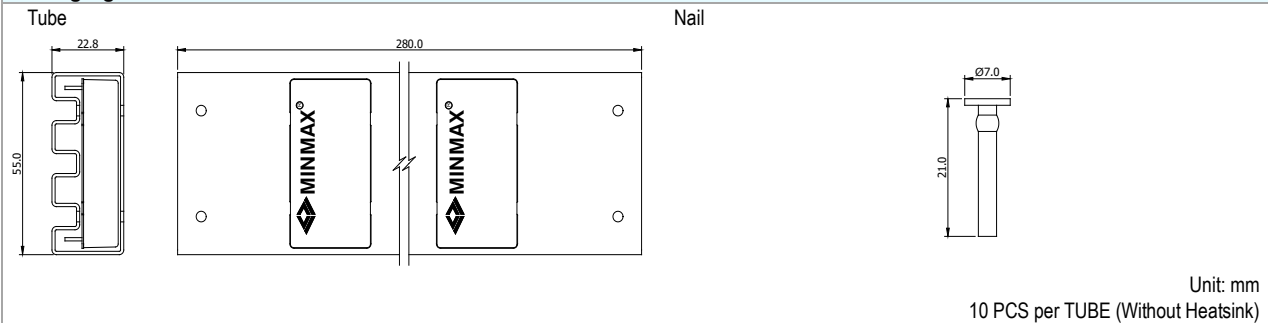

Wave Soldering Considerations

Lead free wave solder profile

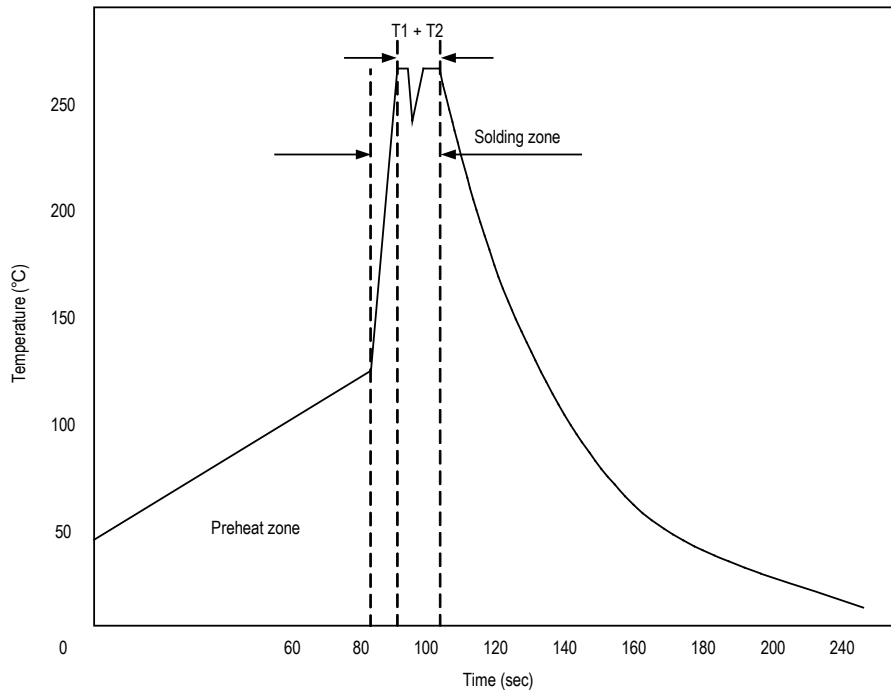

Zone	Reference Parameter
Preheat	Rise temp. speed : 3°C/sec max.
zone	Preheat temp. : 100~130°C
Actual	Peak temp. : 250~260°C
heating	Peak time(T1+T2) : 4~6 sec

Hand Welding Parameter

Reference Solder: Sn-Ag-Cu : Sn-Cu : Sn-Ag

Hand Welding: Soldering iron : Power 60W

Welding Time: 2~4 sec

Temp.: 380~400°C

Part Number Structure

M	K	WI	80	-	24	S	05	N
Package Type 2" X 1"	Ultra-wide 4:1 Input Voltage Range	Output Power 80 Watt	Input Voltage Range 24: 9 ~ 36 VDC 48: 18 ~ 75 VDC		Output Quantity S: Single D: Dual	Output Voltage 05: 5 VDC 12: 12 VDC 15: 15 VDC 24: 24 VDC 48: 48 VDC 54: 54 VDC		Negative logic

MTBF and Reliability

The MTBF of MKWI80 series of DC-DC converters has been calculated using

MIL-HDBK 217F NOTICE2, Operating Temperature 25°C, Ground Benign.

Model	MTBF	Unit
MKWI80-24S05	114,244	Hours
MKWI80-24S12	244,579	
MKWI80-24S15	250,513	
MKWI80-24S24	294,163	
MKWI80-24S48	268,468	
MKWI80-24S54	260,681	
MKWI80-24D12	276,722	
MKWI80-24D15	269,302	
MKWI80-48S05	141,755	
MKWI80-48S12	274,229	
MKWI80-48S15	284,237	
MKWI80-48S24	324,228	
MKWI80-48S48	256,070	
MKWI80-48S54	264,513	
MKWI80-48D12	262,059	
MKWI80-48D15	275,761	